

DA SERIES INSTALLATION MANUAL



CURTIS-TOLEDO, INC.

1905 Kienlen Ave., St. Louis, MO 63133
Tel: (314) 383-1300 Fax: (314) 381-1439
Email: info@curtistoledo.com
Website: www.curtistoledo.com



DA Series Installation instructions

Warning: Before proceeding with installation read and observe following safety precautions.

1. Read entire instruction sheet before beginning installation of the DA Series.
2. Never connect or disconnect a pipeline/line containing air pressure or remove a component ,fitting or pipe plug unless you are certain all air pressure has been exhausted.
3. Always wear proper eye protection when installing or servicing DA Series. Never look directly into ports of the DA Series.
4. Never exceed recommended working air pressure of 175 PSIG
5. Optimum working pressure 100 to175 PSIG.
6. Never attempt to install or service DA Series until you read and understand all recommended procedures.
7. Use only proper tools and observe all procedures pertaining to the use of those tools.

Basic mounting guidelines

1. The DA Series must be mounted with the exhaust ports positioned downward. (Ref. Fig 1.)
2. Power source: 110-120 Volt AC (grounded) electric receptacle required (surge protection recommended) for operation of DA Series.
3. Mount DA Series downstream of air compressor reservoir (Ref. Fig 1)
4. The DA Series should be mounted in a location with sufficient space around it to facilitate service and to provide visual access for a periodic inspection. Allow at least two (2.00) inch clearance above desiccant cartridges for service.
5. Consider installing a series of lines and shut-off valves in conjunction with the installation of the DA Series to provide a by-[pass system of the DA Series. Doing so will provide ability to maintain operation of air system, while future service of the DA Series is being performed.

Mounting DA Series Base Assembly

1. After determining proper location for DA Series as instructed in the “basic mounting guidelines” section.
2. Mount base assembly at chosen location prior to installing desiccant cartridges. Make sure there will be a minimum two (2.00) inch clearance above desiccant cartridges for future service.

Connecting Air Lines

1. Connect high pressure line (175 psig max) to DA Series inlet port (Ref. Fig.1)
2. Connect DA Series outlet port to system air line (Ref. Fig. 1)

NOTE: Use appropriate thread sealant on air line fittings top prevent air leaks.

Installing desiccant cartridges & Mufflers

1. After Base assembly is mounted, install both desiccant cartridges to base assembly as follows.
 - a) Install O-ring, into groove, of each center thread adaptor in base assembly.
 - b) Lubricate both O-rings and threads.
 - c) Lubricate contact surface of flat gasket located in cartridge plate.
 - d) Start cartridge onto thread adaptor, being careful not to cross thread. Turning cartridge clockwise until flat gasket contacts casting surface. After gasket contact turn cartridge only ½ additional turn.

NOTE: DO not over-tighten cartridge or future removal will be extremely difficult.

2. Install muffler into each exhaust port of the DA Series.

Micro Logic Timer (MLT) electrical connection

1. Plug-in MLT power cord to 110-120 Volt AC grounded receptacle.

NOTE: The MLT device is polarity sensitive. MLT will not operate if power (+) and neutral (-) leads are switched.

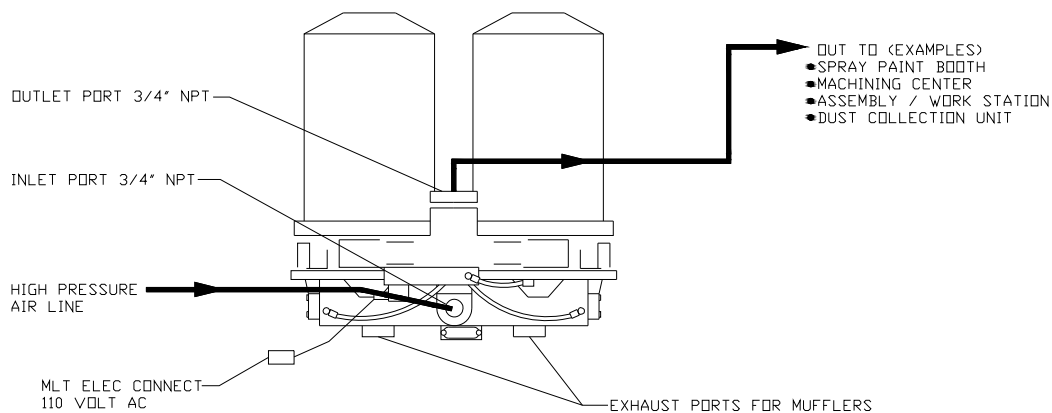

FIGURE 1: Air Connection Schematic

Start-up / Check

1. Ensure that all air line fittings are properly connected.
2. Pressurize system
3. Check air line fittings for leaks and repair leaks.
4. Observe operation of the DA Series for proper function as described in the DA Series Operation /Cycle section.

DA Series operation/Cycle

1. The Micro Logic Timer (MLT) controls drying and regeneration cycles of the DA Series by energizing and de-energizing the "air control valve" of the DA Series at 120 second intervals. A green LED will intermittently light during one (1) cycle and the light continuously during alternate cycle.
2. The DA Series "air control valve" controls air-flow direction through the DA Series. During operation one desiccant cartridge is drying air and the other cartridge is being regenerated.
3. During operation there will be a light flow of air from ONE exhaust port of the DA Series. This is normal regeneration, air flow will alternate (every 120-seconds) from one exhaust port to the other in conjunction with the MLT cycles. There will be a momentary burst of air from one of the exhaust ports, this is normal and is beginning of the regeneration process.

Service Parts for DA Series

Item #	FS Curtis Part Number	Description
220E	640221	20 CFM Twin Canister w/ Timer
230E	640231	30 CFM Twin Canister w/ Timer
240E	640241	40 CFM Twin Canister w/ Timer
220S	640222	20 CFM Twin Canister w/o Timer
230S	640232	30 CFM Twin Canister w/o Timer
240S	640242	40 CFM Twin Canister w/o Timer
C1	CES42CO50	1/2" Coalescing Pre-Filter w/ Internal Drain
C2	CES64CO75	3/4" Coalescing Pre-Filter w/ Internal Drain
C3	CES127C100	1" Coalescing Pre-Filter w/ Internal Drain
M2A	619780	Duplex Aluminum Manifold Kit w/Wall Strut
M3A	619785	Triplex Aluminum Manifold Kit w/ Wall Strut
M2S	619945	Duplex Wall Strut w/o Manifold Kit
M3S	619955	Triplex Wall Strut w/o Manifold Kit
Valve Service Kit	619702	(2) Inlet Check Valves (2) Purge Valves (1) Outlet Check Valve
S1	VQF114	Supply Line for 1/2" NPT x 48" w/Fittings
S2	VQF113	Supply Line for 3/4" NPT x 48" w/Fittings
S3	VQF115	Supply Line for 1" NPT x 48" w/Fittings
Desiccant Cartridge Kit	619704	2- Cartridges (canisters)
Regeneration Valve Kit	619708	(2) Valve Kit 20 SCFM
Regeneration Valve Kit	619714	(2) Valve Kit 30 SCFM
Regeneration Valve Kit	619715	(2) Valve Kit 40 SCFM
Safety Valve	619740	Valve 200 PSI
Air Control Valve	619755	(1) Control Valve
Muffler	619772	(1) Muffler Canister
Timer	619790	(1) Timer 115 Volt A.C.
Replacement Element	C42FE	1/2" Coalescing Element
Replacement Element	C64FE	3/4" Coalescing Element
Replacement Element	C127FE	1" Coalescing Element

Trouble shooting for DA Series

Problem:

Heavy air flow from one or both of the DA Exhaust ports (mufflers)

NOTE: Alternating "light" air flow from exhaust port (Muffler) is normal as this presents the regeneration cycle.

Possible Cause	Remedy
Worn purge valve or dirt/ foreign material is stuck in the purge valve	Clean cavities and replace purge valve assembly Part # 619702
Worn inlet check valve	Clean cavity replace valve assembly Part # 619702

Problem:

DA Series cycle will not alternate every two minutes

Possible Cause	Remedy
Micro Logic Timer (MLT) malfunctioning	Contact FSCurtis Customer Service Or a local distributor at 314-383-1300
Air Control valve malfunctioning	Replace Air Control valve part # 619755
Air Line tubing connecting air control valve and valve housing and/or manifold damaged or missing	Replace / Repair air line or tubing

Problem:

Safety Valve opens

Possible Cause	Remedy
Safety Valve Malfunctioning	Replace safety valve part # 619740 200psi
System pressure setting exceeds safety valve setting (200psi)	Reduce system operating pressure

Trouble shooting DA Series Cont.

Problem:

Water in the system

Possible Cause	Remedy
Desiccant Contaminated	Replace Desiccant Cartridges #619704
Micro Logic Timer (MLT) Malfunctioning	Contact FSCurtis Customer Service or a local distributor at 314-383-1300
Air control valve malfunction	Replace air control valve #619755
Malfunctioning regeneration valve	Replace regeneration valves (see P/L)
Air line (tubing) connecting air control valve and valve housing and/or manifold damaged or missing	Repair/replace air lines. Check for leaks at fitting threads
Compressed air usage exceeds drying capacity of the DA Series	Contact FSCurtis Customer service or a local distributor at 314-383-1300
Worn purge valve	Replace purge valve assembly #619702
Exhaust ports in purge valve and valve housing not aligned	Align exhaust ports in purge valve and valve housing

Problem:

Inadequate system air volume after DA Series dryer

Possible Cause	Remedy
Air Flow restriction (New installation)	Contact FSCurtis Customer Service or a local distributor at 314-383-1300
Desiccant cartridges restricted	Replace desiccant cartridges.

Instruction to add secondary unit to existing control unit:

WARNING: BEFORE PROCEEDING WITH INSTALLATION READ AND OBSERVE FOLLOWING SAFETY PRECAUTIONS:

1. Read entire instruction sheet before beginning installation of DA Series.
2. Never connect or disconnect a pipe/line containing air pressure or remove a component, fitting or pipe plug unless you are certain all air pressure has been exhausted.
3. Always wear proper eye protection when installing or servicing the DA Series. Never look directly into ports of DA Series.
4. Never exceed recommended working air pressure of 175 psig.

Revision to existing control unit:

1. Remove & discard two (2) 90 deg. fittings located in seal retainers located on each end of valve housing and replace the 90 deg. fittings with tee fittings supplied.

NOTE: Fittings must be installed in rear retainer ports.

Install secondary unit next to control unit and make appropriate inlet & outlet air line connections.

Connecting ¼" air lines from DA Series control unit to DA Series secondary unit (see below)

1. Install ¼" air line to connect left rear tee fitting of control unit to 90 deg. fitting located in left rear retainer of DA Series secondary unit.
2. Install ¼" air line to connect right rear tee fitting of control unit to 90 deg. fitting located in right rear seal retainer of DA Series secondary unit.

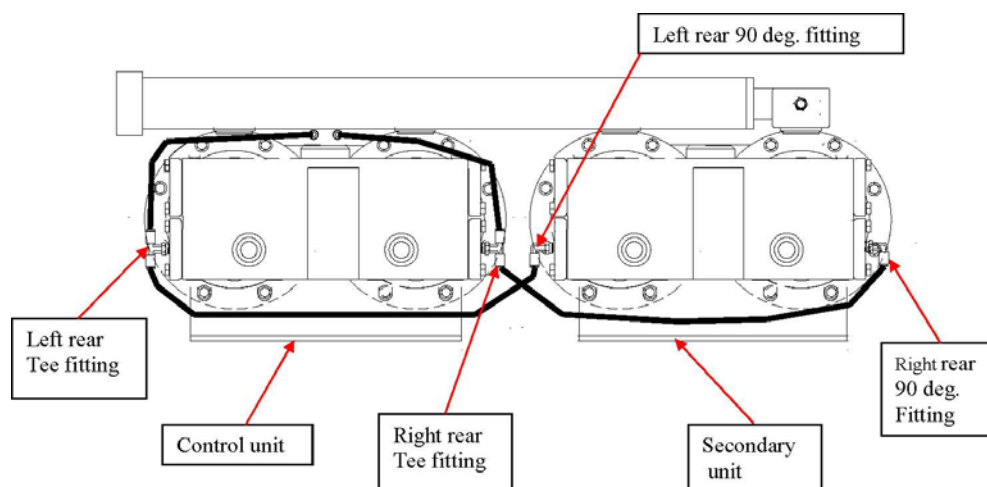

INSTALLING DESICCANT CARTRIDGES & MUFFLERS

After base assembly is mounted, install desiccant cartridges to base assembly as follows:

1. Install o-ring into groove of each center thread adaptor in base assembly.
2. Lubricate both o-rings and threads.
3. Lubricate contact surface of flat gasket located in cartridge plate.
4. Start cartridge onto thread adaptor, being careful not to cross thread. Turn cartridge clockwise until flat gasket contacts casting surface. After gasket contact turn cartridge only ½ additional turn.

NOTE: Do not over-tighten cartridge or future removal will be difficult.

5. Apply ant-seize compound to muffler threads & install a muffler into each exhaust port of the DA Series.

MICRO LOGIC TIMER (MLT) ELECTRICAL CONNECTION

1. Plug-in MLT power cord to 110-120 Volt AC grounded receptacle.

NOTE: The MLT device is polarity sensitive. MLT will not operate if power (+) and neutral (-) leads are switched.

START-UP/CHECK

1. Ensure that all air lines fittings are properly connected.
2. Pressurize system.
3. Check air line fittings for leaks and repair leaks.
4. Observe operation of the DA Series for proper function as described in the DA Series OPERATION/CYCLE section

DA Series OPERATION/CYCLE

1. The Micro Logic Timer (MLT) controls drying and regeneration cycles of the DA Series by energizing and de-energizing the “air control valve” of the DA Series at 120-second intervals. An indicator light on MLT will be on during energized cycle and off during the de-energized cycle.
2. The DA Series “air control valve” controls air-flow direction through the DA Series. During operation one desiccant cartridge is drying air and other cartridge is being regenerated.
3. During operation there will be a light flow of air from ONE exhaust port of each DA Series unit. This is normal, regeneration, air flow and the air flow will alternate (every 120 seconds) from one exhaust port to the other in conjunction with the MLT cycles. When the DA Series cycle alternates there will be a momentary burst of air from one of the exhaust ports. This is normal and is beginning of regeneration process.

CURTIS-TOLEDO® , INC.

1905 Kienlen Ave. , St. Louis, Missouri 63133

ph: 314-383-1300 fax: 314-381-1439

website: www.curtistoledo.com

email: info@curtistoledo.com